

SSI ECD350 Disc Diffuser Systems— A Global Success Story

SSI ECD350 (12") Disc Diffuser systems combine engineering excellence, superior component quality, and a technically advanced product concept. Unibody plastic construction means the diffuser is a single piece. Because of unique SSI developments related to product design and production automation, you can purchase this high quality diffuser for an economical price. You get the same high quality membrane that SSI is known for. The plastic material is made from the highest-quality, sorted recycled polypropylene resin. When the time comes to replace the diffuser, simply unscrew the old one and screw a new one in. Replacement is clean and quick, and because it is made of recycled plastic, it is also environmentally friendly. Oxygen transfer and headloss performance are equal to the current SSI product line, because we have not changed the membrane or the orifice diameter of diffuser.

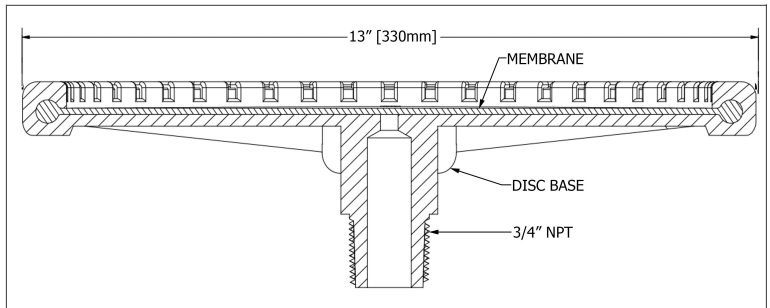

Unique System Strengths

Complete product line – creating the system that fits your needs

SSI manufactures disc diffusers and coarse bubble diffusers, and we mount these products on a wide range of piping materials including PVC, CPVC, PP and Stainless Steel. We have the ability to attach diffusers to pipe using saddles, grommets, or pre-assembled PODS. We can provide retrievable systems or fixed grids, and systems in kit form or mostly factory assembled. We try to understand and anticipate your needs, and fit our recommendations to your situation.

Piping system integrity – thicker wall pipe and double anchors for fewer breakages

Our piping is 38% thicker and has double rod support stands as standard – two anchors for each support location means twice the resistance to hydraulic and thermal loads. Most often supports fail due to temperature and water velocity. SSI locates two anchors where support is needed most, helping to increase product longevity.

Comprehensive design service and after sales support

SSI provides full design services, including biological and mixing calculations, process simulations and hydraulic studies. We maintain a full drafting department with 3D and animation capabilities and we can assist with specifications and CAD drawings. Our service and installation crew can hold your hand during the early stages of the project and our worldwide multilingual staff is dedicated to your complete satisfaction.



SSI provides full design services, including biological and mixing calculations, process simulations and hydraulic studies.

Intelligent Upgrade Options

Patented PTFE membranes prolong efficiency and reduce whole-life costs

SSI's patented PTFE membrane barrier properties not only reduce plasticizer extraction, shrinking, and membrane hardening but also limit dynamic changes that can result from swell, such as creep. Compared with uncoated products that are more susceptible to increases in DWP due to more aggressive fouling and changes in physical properties and weight, the PTFE coated membrane improves consistency of DWP (Headloss) values over the product life. This directly impacts long-term power costs and the ability of the system to distribute air uniformly across the tank floor.

Grommet Connection

Simple to install on site, compact to ship and move. Affordably priced and time tested over 15 years worldwide.

Quick Threaded Saddle

QTS saddles quickly and easily bolt onto the pipe and allow installation of the diffuser with a few simple turns.

Avg Operating Condition per Diffuser	Peak Air Flow per Diffuser	Orifice Size	Slit Qty	Active Surface Area per Diffuser	Weight per Diffuser ECD350
0.8 - 4.0 SCFM 1.35 - 7.0 Sm ³ /hr	7.0 SCFM 12.0 Sm ³ /hr	3/8" 10mm	+/- 10,155	0.70 ft ² 0.0650 m ²	1.3 lbs 0.6 kg

Operating diffusers distant to average operating conditions range might leads to poor uniform distribution and subjected to rapid fouling.

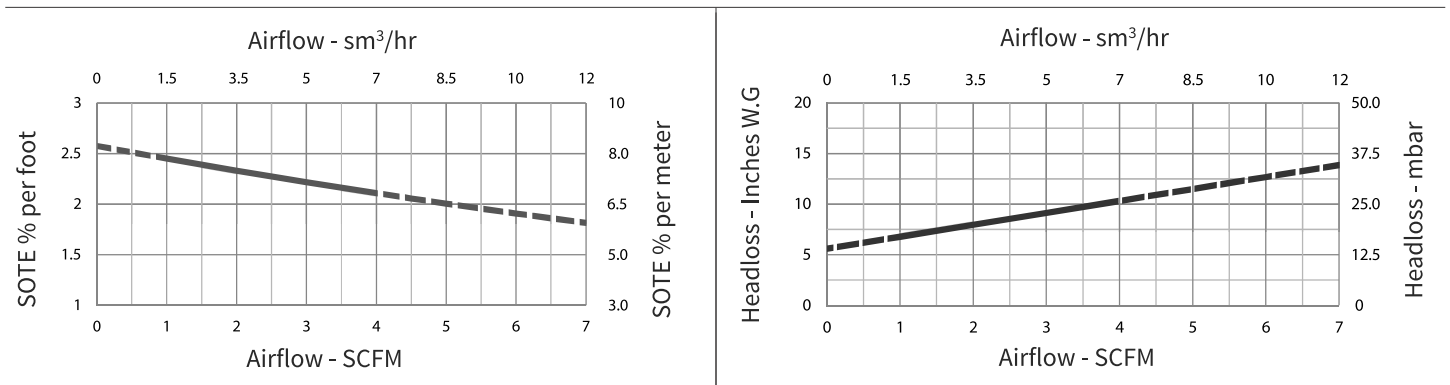

Above curves are generated based on ideal condition. Actual curves for specified project/condition to be provided upon request.