

# The SSI ReliaBall™ Coarse Bubble Diffuser System is a World Wide Winner

The SSI Coarse Bubble Diffuser System is called ReliaBall™ for a reason. It combines engineering excellence, superior component quality, and a technically advanced product design. Proven highly durable and efficient in thousands of municipal and industrial installations around the world, SSI Aeration's ReliaBall™ is a name to trust.

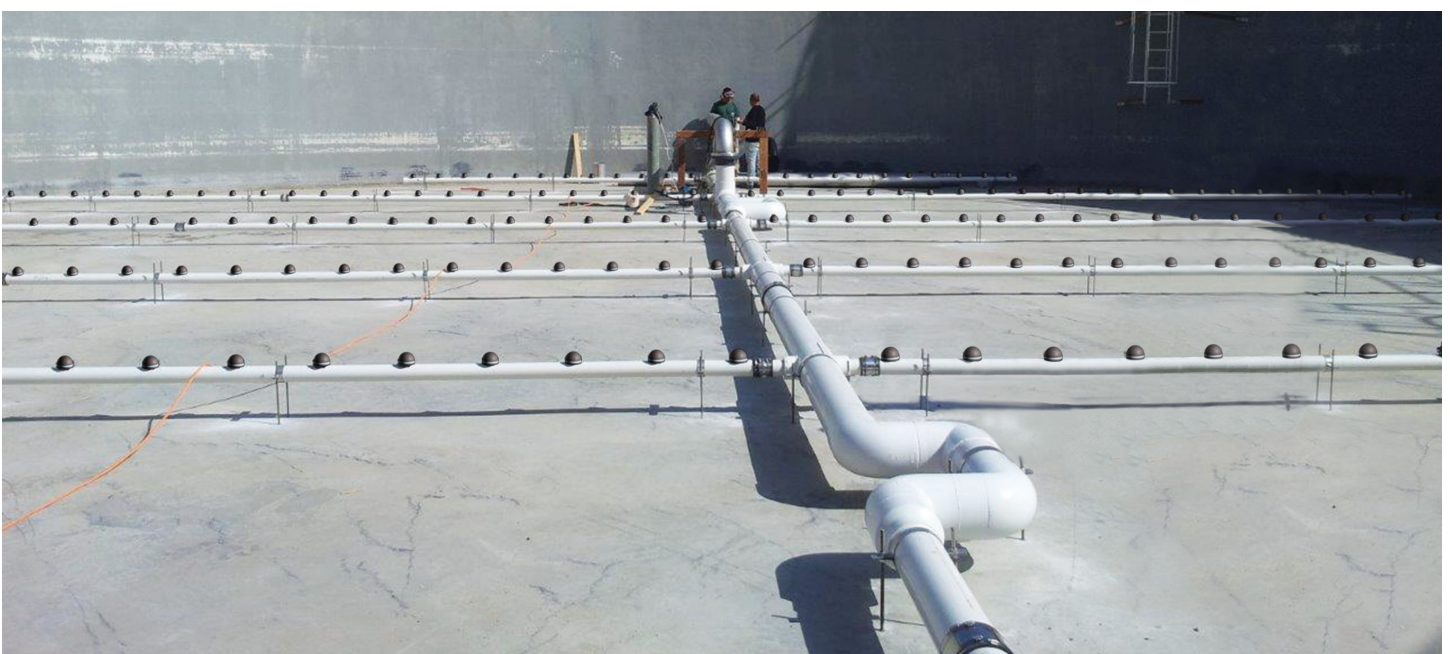

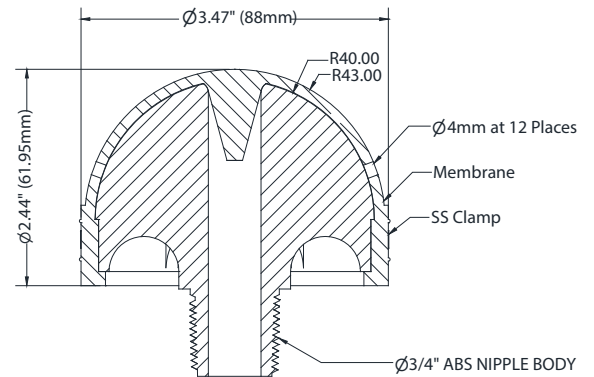
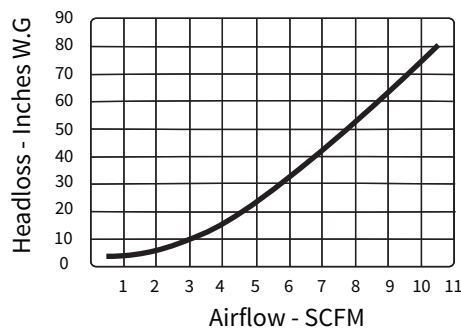
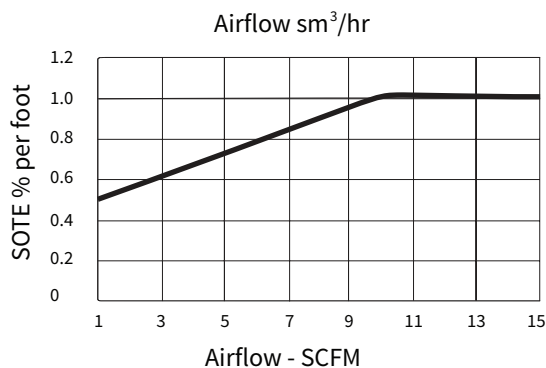

## Unique System Strengths

### Complete product line – creating the system that fits your needs

SSI manufactures disc diffusers and coarse bubble diffusers, and we mount these products on a wide range of piping materials including PVC, CPVC, PP and Stainless Steel. We have the ability to attach diffusers to pipe using saddles, grommets, or pre-assembled PODS. We can provide retrievable systems or fixed grids, and systems in kit form or mostly factory assembled. We try to understand and anticipate your needs, and fit our recommendations to your situation.

### Piping system integrity – thicker wall pipe and double anchors for fewer breakages

Our piping is 38% thicker and has double rod support stands as standard – two anchors for each support location means twice the resistance to hydraulic and thermal loads. Most often supports fail due to temperature and water velocity. SSI locates two anchors where support is needed most, helping to increase product longevity.

### Comprehensive design service and after sales support

SSI provides full design services, including biological and mixing calculations, process simulations and hydraulic studies. We maintain a full drafting department with 3D and animation capabilities and we can assist with specifications and CAD drawings. Our service and installation crew can hold your hand during the early stages of the project and our worldwide multilingual staff is dedicated to your complete satisfaction.

## Intelligent Upgrade Options

### Patented PTFE membranes prolong efficiency and reduce whole-life costs

SSI's patented PTFE membrane barrier properties not only reduce plasticizer extraction, shrinking, and membrane hardening but also limit dynamic changes that can result from swell, such as creep. Compared with uncoated products that are more susceptible to increases in DWP due to more aggressive fouling and changes in physical properties and weight, the PTFE coated membrane improves consistency of DWP (Headloss) values over the product life. This directly impacts long-term power costs and the ability of the system to distribute air uniformly across the tank floor.

### SSI Telemetry – the inside story solves maintenance problems

At the click of a mouse, you will know the DWP of your diffuser membranes, airflow rate to those monitored diffusers, and air temperature in the submerged piping system. You can sense vibration, pipe roll over, and water in the grid. Automatic moisture purging and automatic acid dosing systems are available. Through multiple cameras, you can see both inside the grids, and surface bubble patterns. Wet probes are also available for DO and WW temperature. Tracking all this data on a user-friendly online dashboard facilitates communication between consultant and client, manufacturer and rep. This smart technology lets you locate problem areas and allocate resources more efficiently. SSI Telemetry is your preventive maintenance hub in the heart of the plant.

SSI manufactures disc diffusers, tube diffusers, a variety of coarse bubble diffusers, and we mount these products on a wide range of piping materials including PVC, CPVC, PP, and Stainless Steel. We have the ability to use saddles, threaded connections, grommets, or push-on/interference fit methods to attach diffusers to pipe.

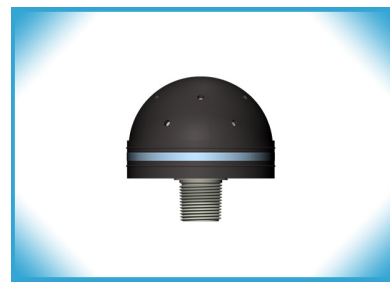

### Grommet Connection

Simple to install on site, compact to ship and move. Affordably priced and time tested over 15 years worldwide.